

Keyboard is pattern on front of PCB.

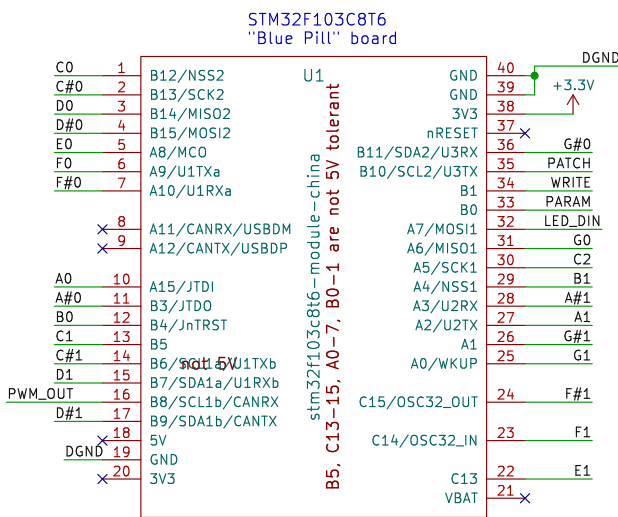

STM32F103C8T6 "Blue Pill" board

stm32f103c8t6-module-china
B5, C13-15, A0-7, B0-1 are not 5V tolerant

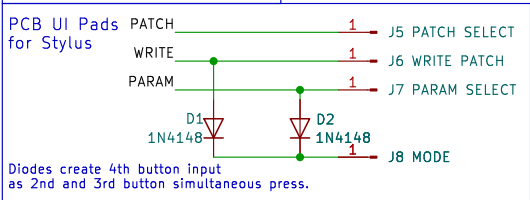
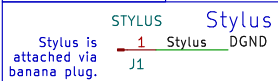
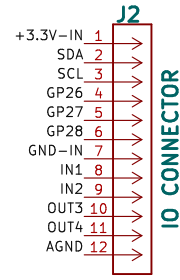
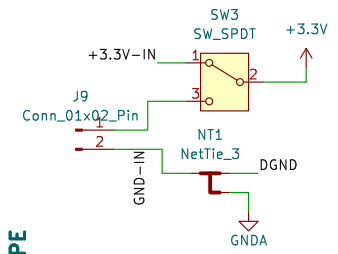
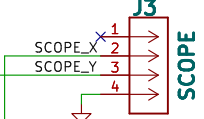
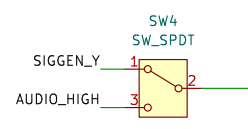
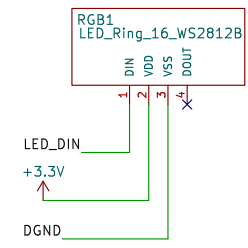

Connection as recommended by Application Design Guidelines for LM324 and LM358 Devices, Figure 7-1

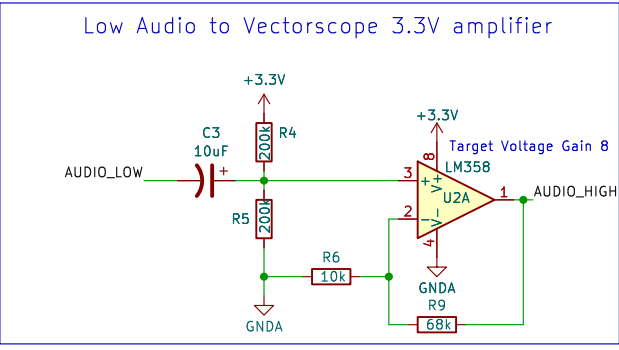
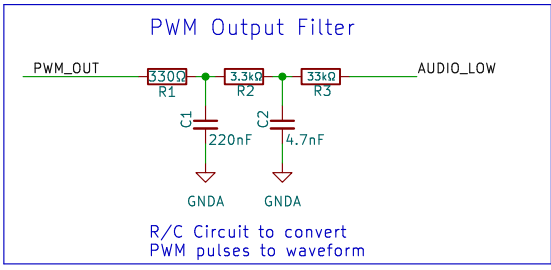
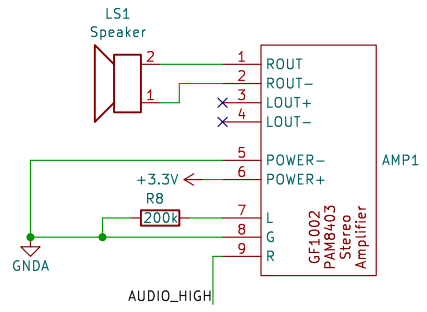
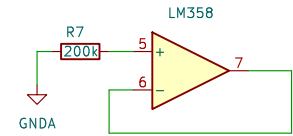

Version 0.5 - SEGFAULT 2025-02-02
Version 0.4 - T. B. Trzepacz @ SoftEgg 2024-4-11
Version 0.3 - Thea @ Aisler 2024-4-8
Version 0.2 - T.B. Trzepacz @ SoftEgg 2024-4-7

SoftEgg
Sheet: /
File: vectorscope-synth.kicad_sch

Title: Vectorscope Synthesizer

Size: A4	Date: 2025-02-02	Rev: 0.5
KiCad E.D.A. 8.0.8		Id: 1/1