

STERLING



Linear Scales

Installation Manual

Sterling's KA series of glass scales are designed and manufactured to deliver the optimal structure for rigidity with ease of installation and high precision. A modular range of accessory installation brackets make installations fast, easy, and accurate without the need to fabricate on site. Please refer to the following pages for installation and service data.

1. Technical Specification:

- a. Pitch: 0.02mm (50 lines/mm)
- b. Resolution: 1 μ m and 5 μ m
- c. Accuracy: $\pm 5\mu$ m and $\pm 10\mu$ m (20°C)
- d. Range: 70 ~ 3000mm
- e. Max. Speed: 60 or 120m/min
- f. Working Voltage: +5V ($\pm 5\%$) 80mA
- g. Cable Length: 3m (various length available upon request)
- h. Working Temperature: 0 ~ 45°C

i. Plug Pin

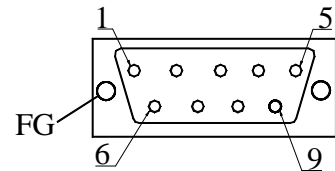

- 1) Applicable to the EIA-442-A signals output of KA-300, KA-500 and KA-600 NC scales using 9-pin sockets.

Pin	1	2	3	4	5	6	7	8	9
Signal	\bar{A}	OV	\bar{B}	Null	\bar{Z}	A	+5V	B	Z
Color	Green	Black	Blue	Red	Brown	Yellow	Pink	Orange	White

FG : Connected to metal case for shielding.

2) Applicable to the TTL signal output of KA-300, KA-500 and KA-600 scales using 9-pin sockets.

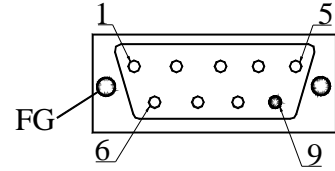

Pin	1	2	3	4	5	6	7	8	9
Signal	Null	OV	Null	Null	Null	A	+5V	B	Z
Color		Black				Green	Brown	Orange	White

FG : connected to metal case for shielding.

3) Applicable to the TTL signal output of KA-300, KA-500 and KA-600 scales with 7-pin sockets.

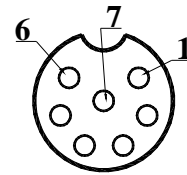

Pin	1	2	3	4	5	6	7
Signal	OV	Null	A	B	+5V	Z	Screen
Color	Black		Green	Orange	Brown	White	

j. Signal Specification

The TTL signal output:

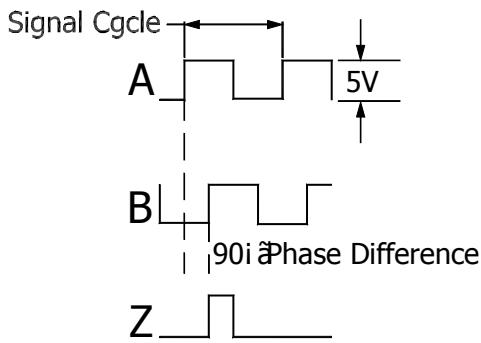

The EIA-442-A signal output:

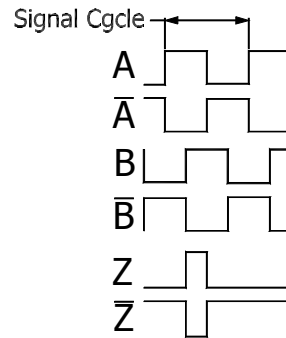

k. Zero-Point Position: one every 500mm.

j. Cycle of the pulse signal output by grate scale (pw)

Resolution	Equivalent weight(pw)
5µm	20µm
1µm	4µm

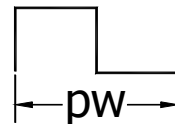

2. Scale Structure:

The glass scale is composed mainly of the glass assembly and the reading head assembly (See Fig. 1).

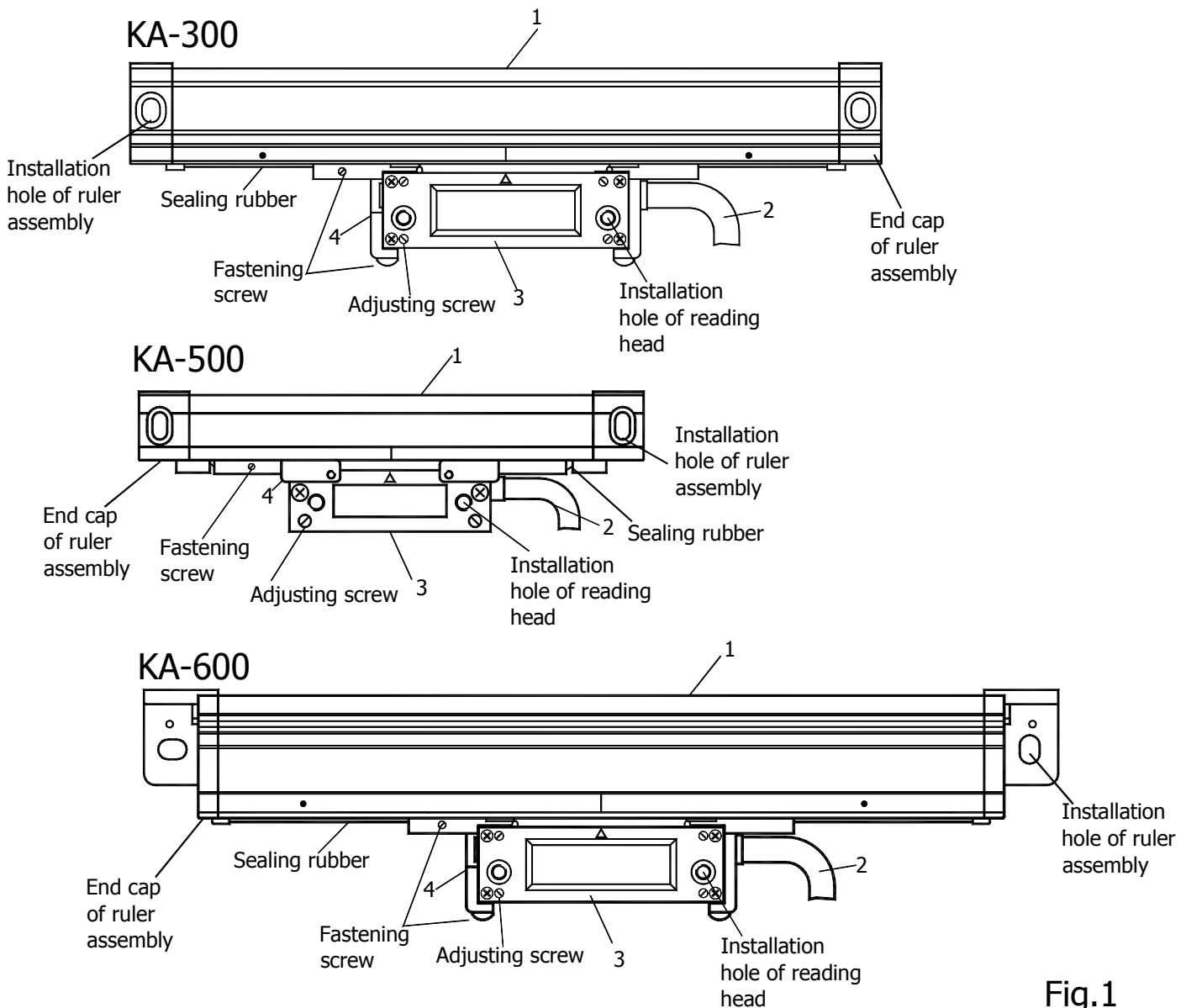

Fig.1

1. Scale Assembly
2. Cable
3. Reading Head
4. Fixed Junction Plate for Reading Head

3. Spare Parts

In order to install and apply the scales in various places, the company designs the following spare parts for them.

- 3.1 Cover Type A, for installation on finished surface, oil resistant and scrap proof (See Fig. 2).
- 3.2 Cover Type B and H, for installation on finished or unfinished surface, oil resistant and scrap proof, applicable to installation surface shorter than scales, contributive to the scale rigidity (See Fig. 3 and Fig. 7).
- 3.3 Economical Cover Type C, I and J, for installation on finished surface, a little inferior to Type A in liquid and scrap resistance (See Fig. 4, Fig. 8 and Fig. 10).
- 3.4 Economical Cover Type D and G, for installation on finished or unfinished surface, applicable to installation surface shorter than scales, a little inferior to Type B and H in liquid and scrap resistance, contributive to the scale rigidity (See Fig. 5).
- 3.5 Bearing Plate, for installation on finished or unfinished surface or surface shorter than scales, contributive to scale rigidity, not resistant to oil or scrap (See Fig. 6 and Fig. 9).

The user may select suitable parts according to the working environment and the installation condition.

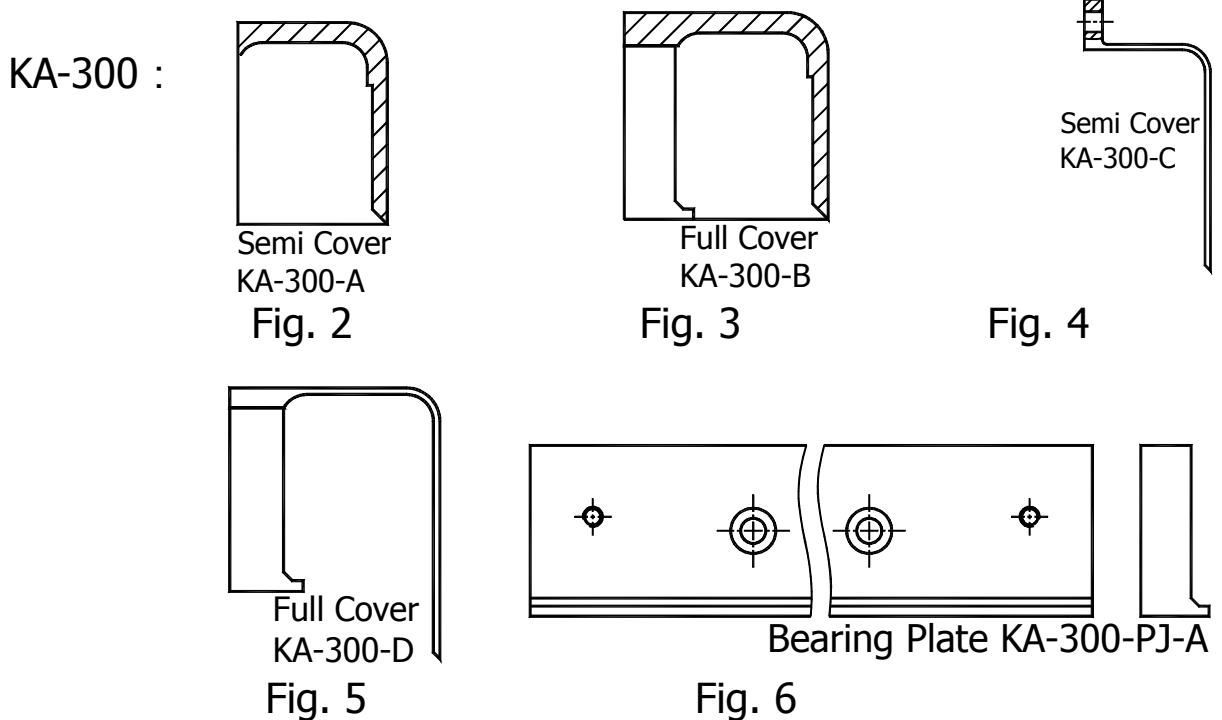

KA-500 :

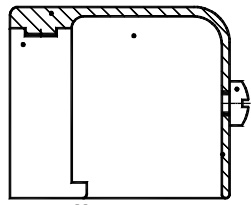

Full Cover
KA-500-H

Fig. 7



Semi Cover
KA-500-I

Fig. 8

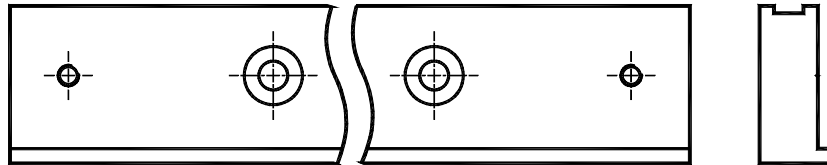

Bearing Plate KA-500-PJ-B

Fig. 9

KA-600 :

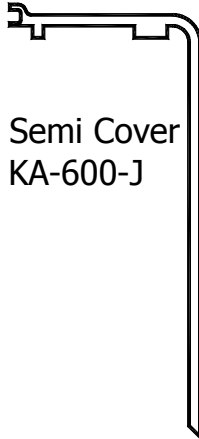

Semi Cover
KA-600-J

Fig. 10

4. Installation

4.1 Installation Dimension

Dimensions of KA-300 glass scale

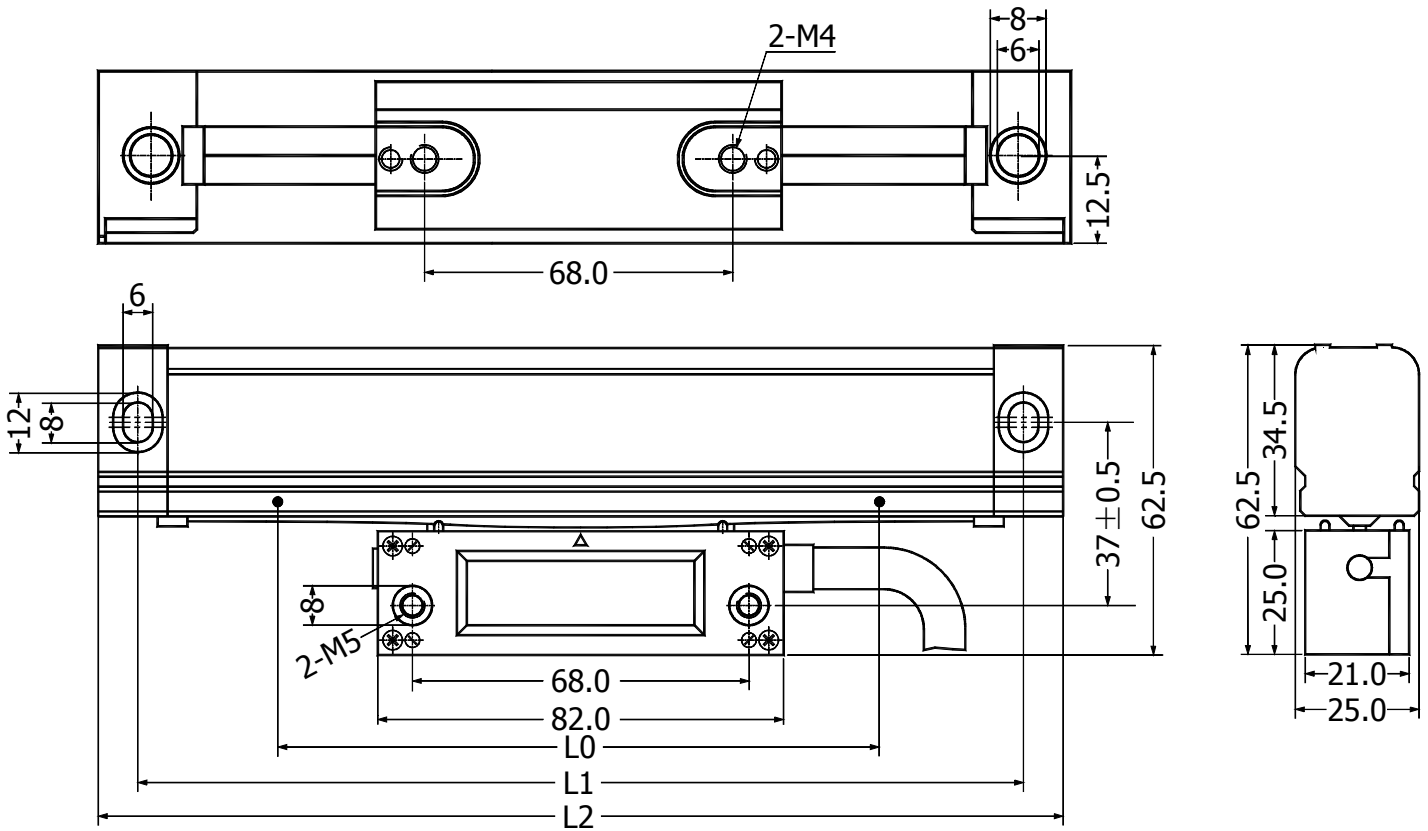

Fig. 11

Model	L0	L1	L2	Model	L0	L1	L2
KA300-70	70	160	176	KA300-570	570	660	676
KA300-120	120	210	226	KA300-620	620	710	726
KA300-170	170	260	276	KA300-670	670	760	776
KA300-220	220	310	326	KA300-720	720	810	826
KA300-270	270	360	376	KA300-770	770	860	876
KA300-320	320	410	426	KA300-820	820	910	926
KA300-370	370	460	476	KA300-870	870	960	976
KA300-420	420	510	526	KA300-920	920	1010	1026
KA300-470	470	560	576	KA300-1020	1020	1110	1126
KA300-520	520	610	626				

Dimensions of KA-500 glass scale

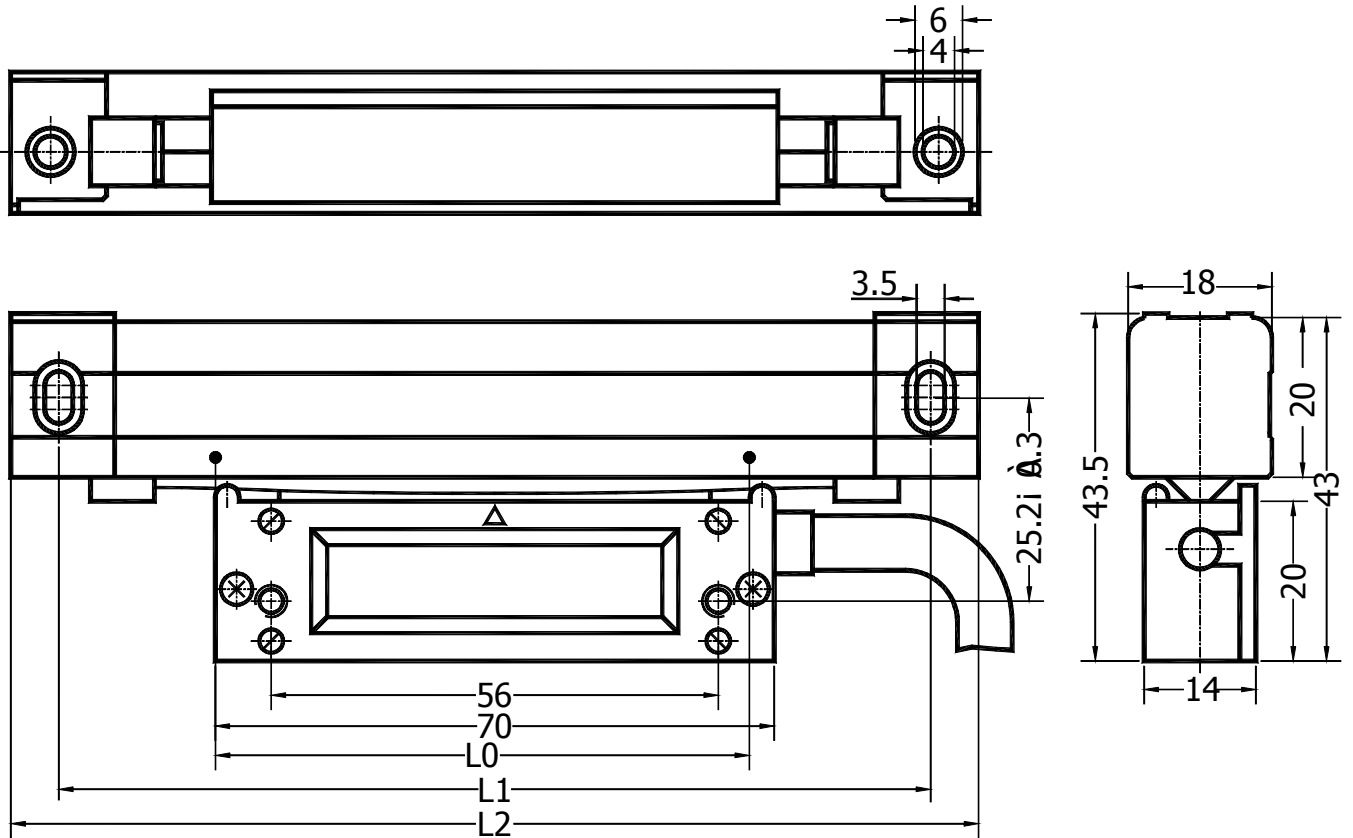

Fig. 12

Model	L0	L1	L2	Model	L0	L1	L2
KA500-70	70	172	182	KA500-320	320	422	432
KA500-120	120	222	232	KA500-370	370	472	482
KA500-170	170	272	282	KA500-420	420	522	532
KA500-220	220	322	332	KA500-470	470	572	582
KA500-270	270	372	382				

Dimensions of KA-600 glass scale.

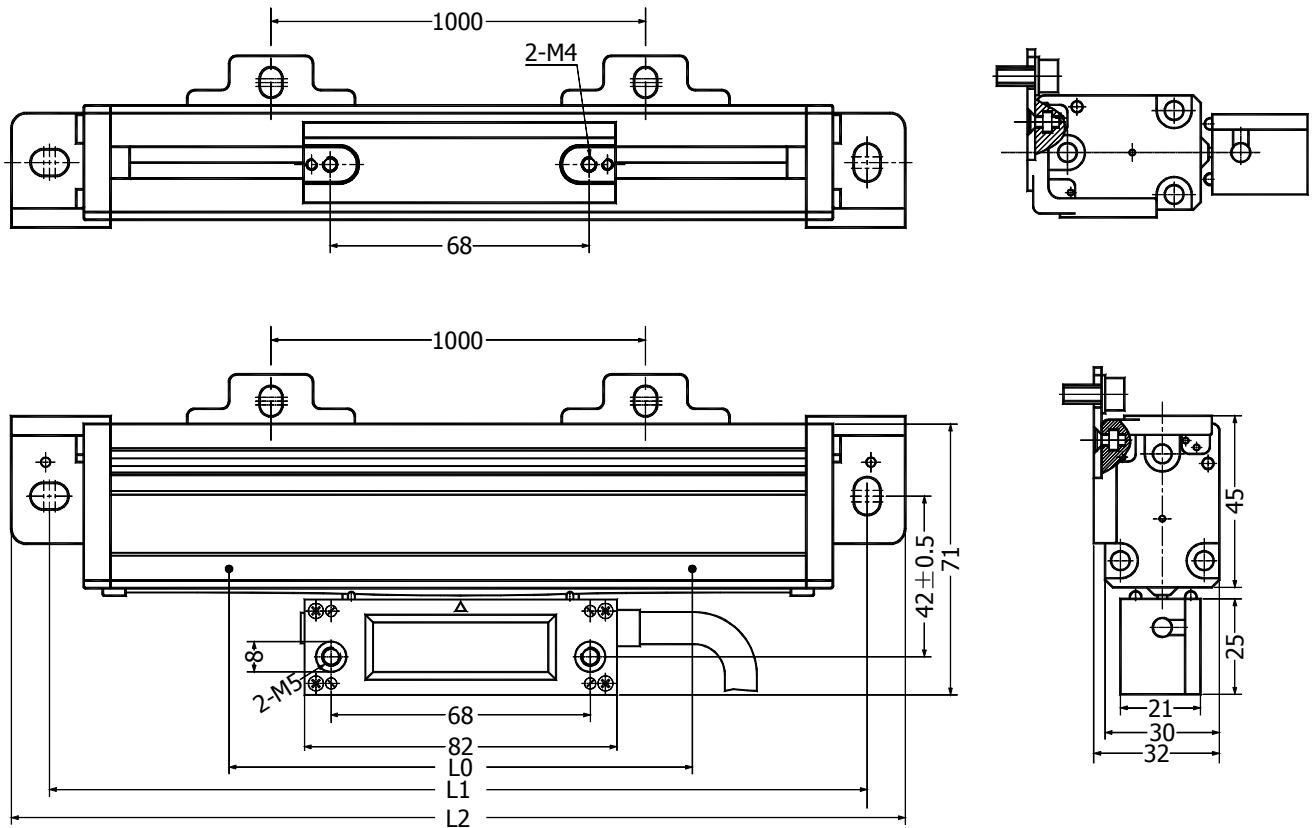

Fig. 13

Model	L0	L1	L2	Model	L0	L1	L2
KA600-1000	1000	1150	1170	KA600-2100	2100	2250	2270
KA600-1100	1100	1250	1270	KA600-2200	2200	2350	2370
KA600-1200	1200	1350	1370	KA600-2300	2300	2450	2470
KA600-1300	1300	1450	1470	KA600-2400	2400	2550	2570
KA600-1400	1400	1550	1570	KA600-2500	2500	2650	2670
KA600-1500	1500	1650	1670	KA600-2600	2600	2750	2770
KA600-1600	1600	1750	1770	KA600-2700	2700	2850	2870
KA600-1700	1700	1850	1870	KA600-2800	2800	2950	2970
KA600-1800	1800	1950	1970	KA600-2900	2900	3050	3070
KA600-1900	1900	2050	2070	KA600-3000	3000	3150	3170
KA600-2000	2000	2150	2170				

L0: Effective metering length

L1: Distance between installation holes

L2: Full scale length

Attentions:

- a. The selection of the gauged scale length depends on the travel length of the machine. The gauged scale length must be longer than the maximum travel length of the machine.**
- b. Proper spare parts shall be adopted according to the given installation length and surface.**
- c. The KA-600 scale shall be equipped with a hook every 1000mm, i.e. 2 for $1000 \leq L < 2000$, 3 for $2000 \leq L < 3000$ and 4 for $L = 3000$.**

4.2 Priorities in Installation

The scale shall use the leading rail of the machine as datum and be installed in parallel to it.

- a. The center of the scale range shall be aligned to that of the travel length of the machine and the scale range shall be able to cover the maximum travel length of the machine.
- b. The scale shall be installed in the proximity of the transmission screw of the machine. In most cases, the installed scale assembly shall move together with the working platform and the reading head is fixed on the machine.
- c. The installed scale shall not obstruct the operation of the machine or compromise the machine's performance.
- d. The installed scale shall not be exposed to any impact hazards. During production, the scale shall not stand in the way of machine handles, brakes or other outstanding parts and shall not be touched when loading or unloading work pieces.
- e. The scale shall be installed vertically or horizontally as shown in Fig. 14. Never install upside down (with the reading head over the scale assembly). The sealing rubber of the scale assembly must be kept away from the cooling oil nozzle of the machine.

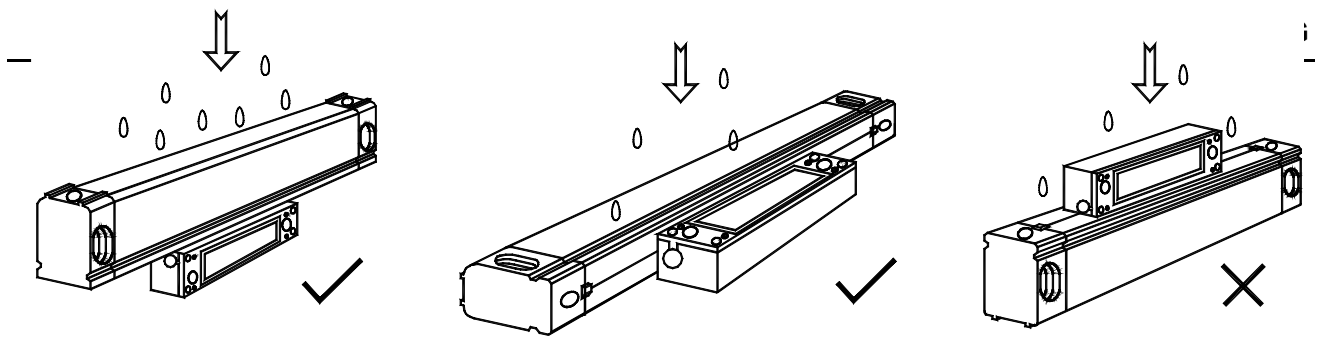

Fig. 14

4.3 Installation of the Scale and Scale Cover

(1) Installation of Scales with Cover Type A

- a. Choose the proper installation position
- b. Mark out and drill M4 screw holes on the installation surface according to the given installation length.
- c. Install the scale assembly to the installation surface loosely, check with a micrometer the parallelism of the scale to the machine's leading rail, and adjust the parallelism well. (See Fig. 15)
- d. Wrench tight the scale assembly to the installation surface.
- e. Adjust the fastening screws of the reading head till they touch the installation surface.
- f. Drill M4 screw holes in line with the installation holes of the reading head.
- g. Wrench tight the reading head and remove the junction plate.
- h. Drill M4 screw holes in line with the installation holes of the scale cover.
- i. Fix the cover to the installation surface and wrench tight.

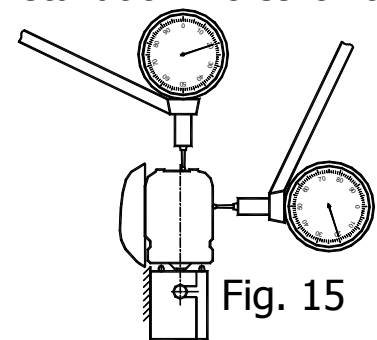
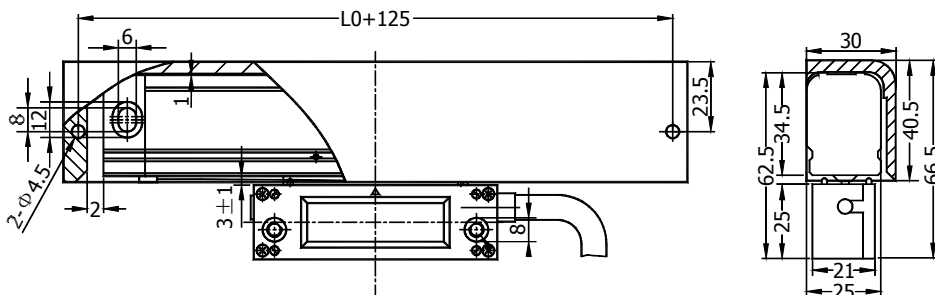

Fig. 15



For installation dimensions, see Fig. 17, Fig. 18 and Fig. 19.

(2) Installation of Scales with Cover Type C, I and J

See Installation of Scales with Cover Type A.

Scale with Cover KA-300C:

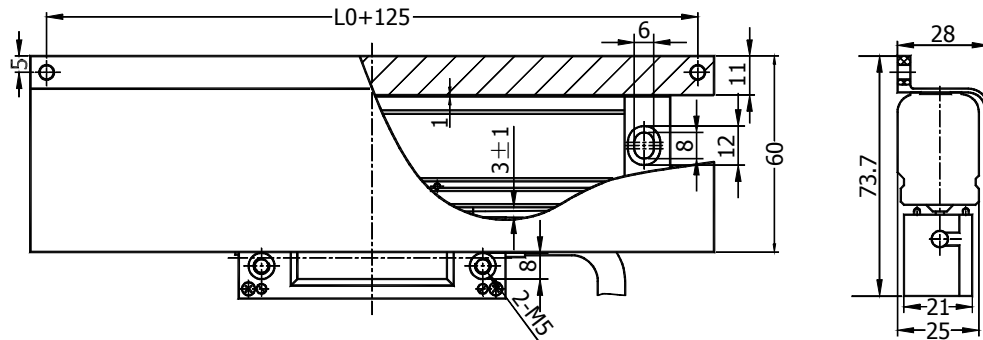

Scale with Cover KA-500I:

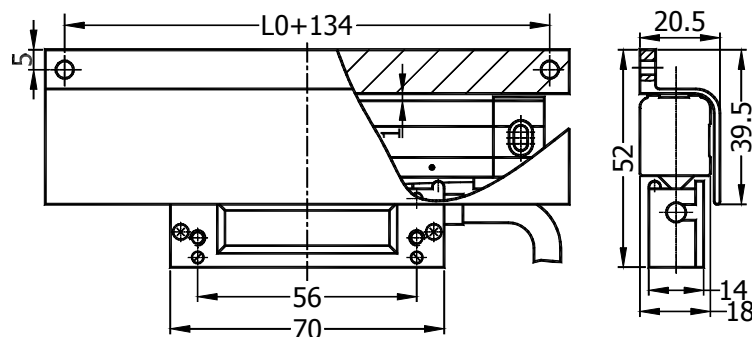

Scale with Cover KA-600J:

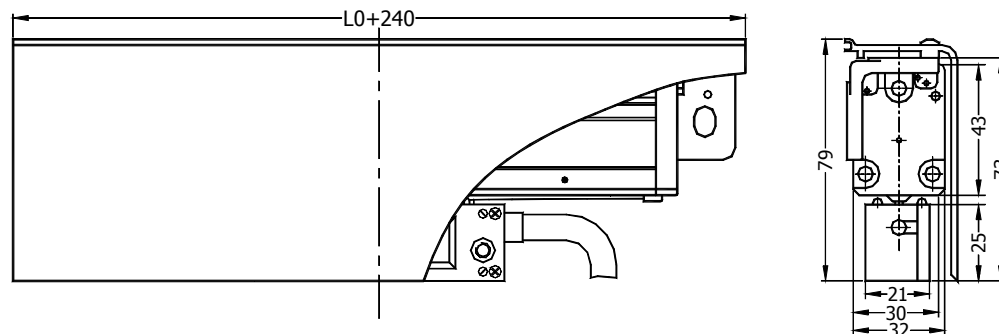

For installation dimensions, see Fig. 17, Fig. 18 and Fig. 19.

(3) Installation of Scales with Cover Type B

- Choose the proper installation position
- Mark out and drill M4 screw holes on the installation surface according to the installation dimension of scale cover type B.
- Fix the strengthening plate of the cover to the installation surface loosely, check with a micrometer the parallelism of the

scale to the machine's leading rail, and adjust the parallelism well (See Fig. 16).

- d. Wrench tight the strengthening plate to the installation surface.
- e. Install the scale assembly to the strengthening plate.
- f. Adjust the fastening screws of the reading head till they touch the installation surface.
- g. Drill M4 screw holes in line with the installation holes of the reading head.
- h. Wrench tight the reading head and remove the junction plate.
- i. Drill M4 screw holes in line with the installation holes of the scale cover.
- j. Fix the cover to the strengthening plate and wrench tight.

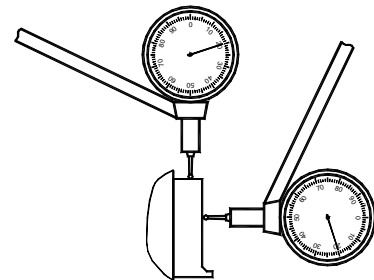
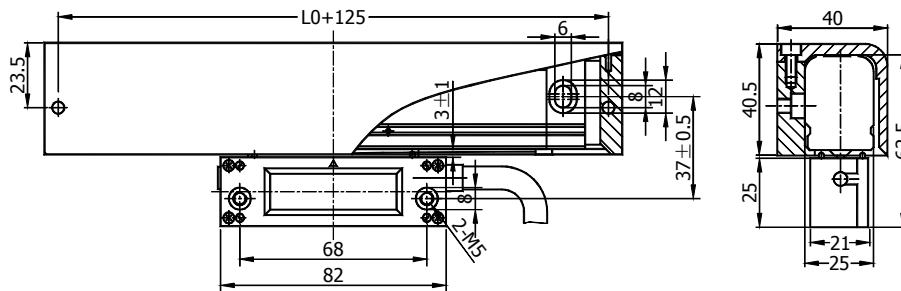

Fig. 16



For installation dimensions, see Fig. 17, Fig. 18 and Fig. 19.

(4) Installation of Scales with Cover Type D and G

See Installation of Scales with Cover Type B and H.

Scale with Cover KA-300D:

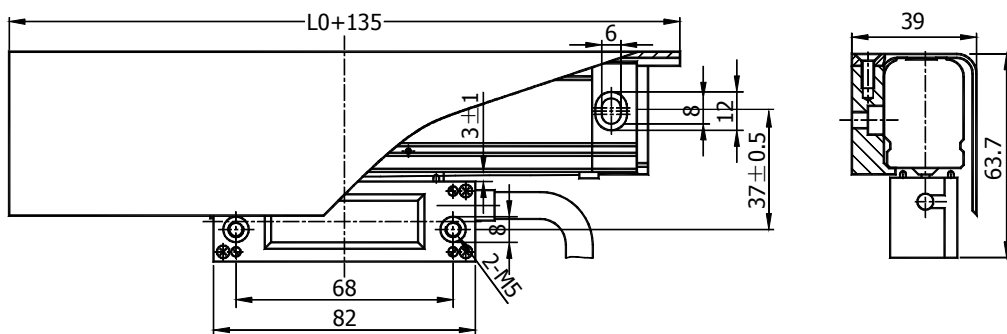

Scale with Cover KA-500G:

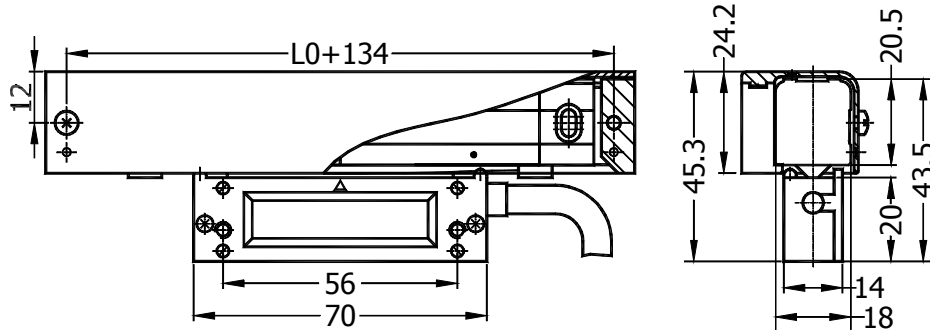

For installation dimensions, see Fig. 17, Fig. 18 and Fig. 19.

KA-300 :

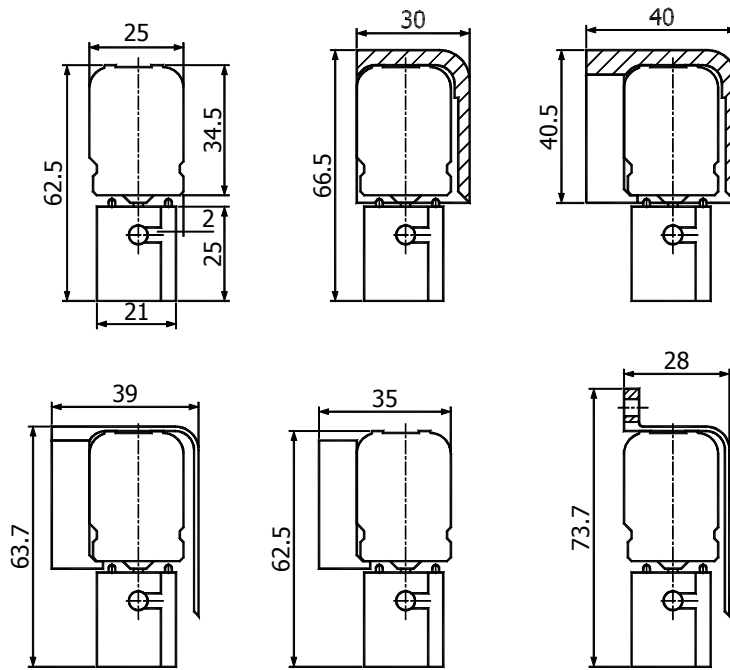

Fig. 17

KA-500:

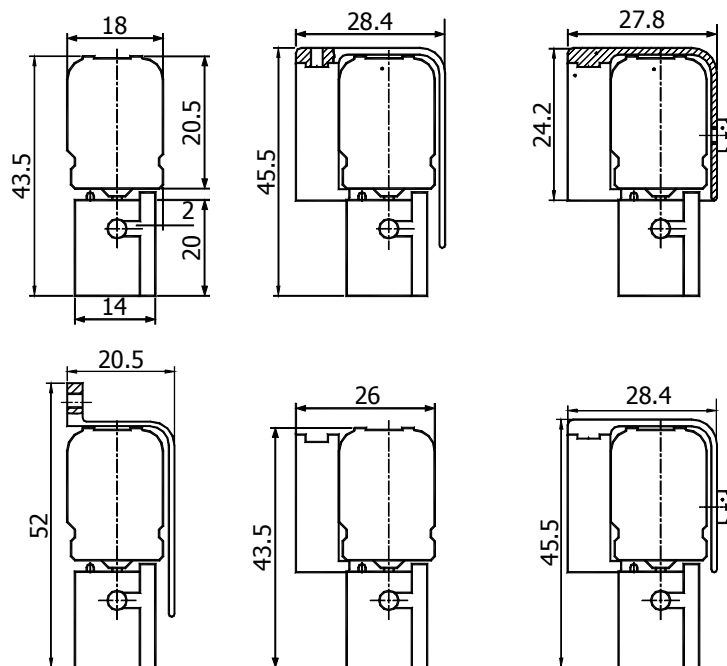

Fig. 18

KA-600 :

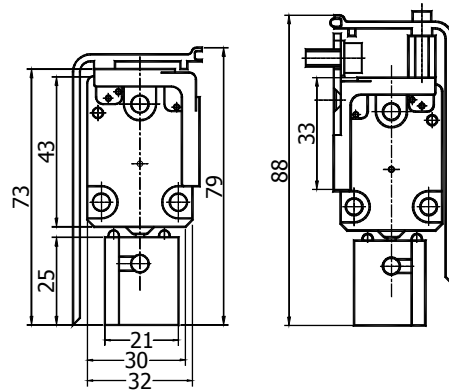

Fig. 19

4.4 Installation of the Reading Head

The reading head can be installed on finished or unfinished surface in a normal or converse way. Only in case of limited installation space, can it be installed conversely.

(1) Normal Installation

Fig. 20 illustrates the normal installation of the reading head. For installation procedure, see Installation of Scale and Scale Cover.

(2) Converse Installation

Fig. 21 illustrates the converse installation of the reading head. The installation procedure is given below:

Note: The following are rather typical installations of the device. The users may make their own combination and arrangement according to the actual situation.

- a. Fix a T frame (optional) to the machine.
- b. Remove the fixed junction plate of the reading head.
- c. Adjust the fastening screws of the T frame installation plate till they touch the reading head.
- d. Fix the reading head with M5 screws to the T frame installation plate.
- e. Adjust the T frame plates till the relative position of the reading head to the scale assembly is as shown in Fig 21.
- f. Install the scale by making use of the T frame (See Fig. 22 – Fig. 31. A: Plate A of T frame; B: Plate B of T frame; C: Extension plate C of T frame; D: Extension plate D of T frame; and E: Part E of T frame).

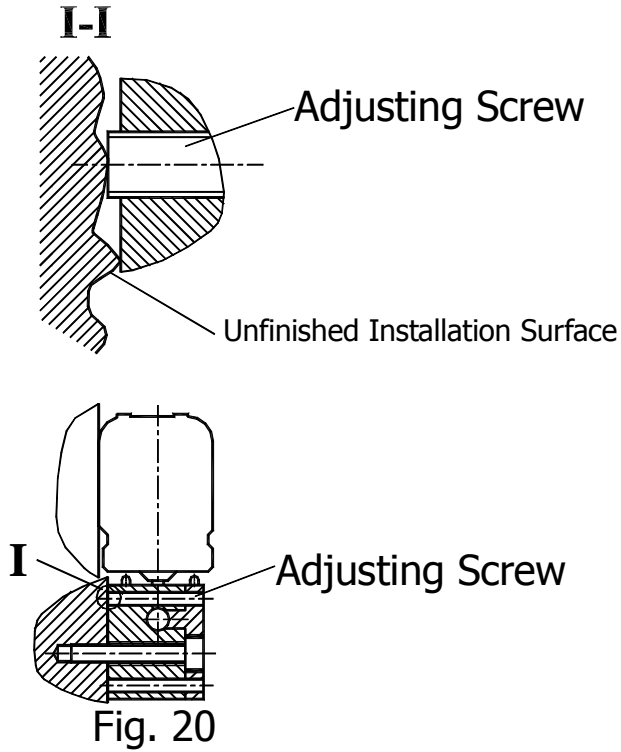

Fig. 20

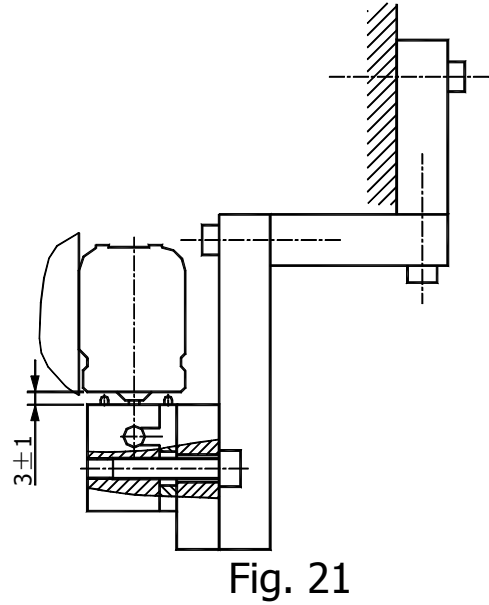

Fig. 21

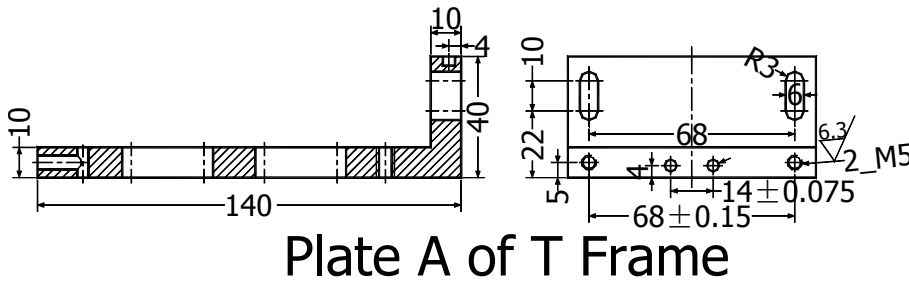

Plate A of T Frame

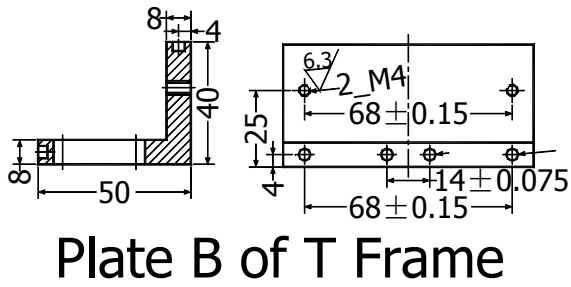
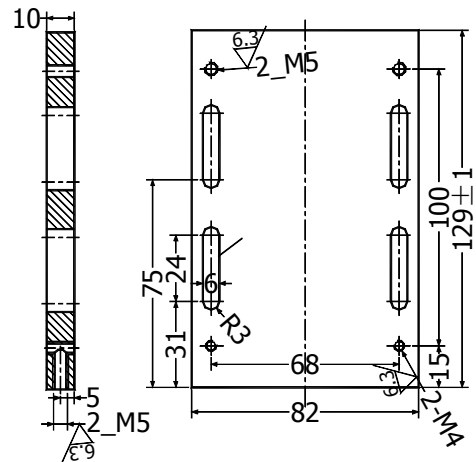
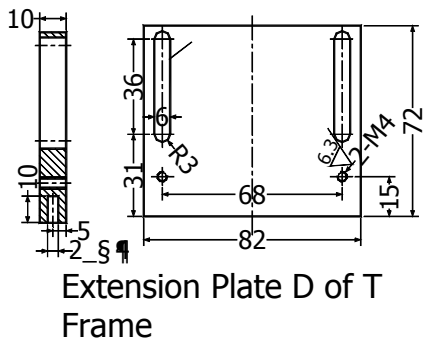

Plate B of T Frame



Extension Plate C of T Frame



Extension Plate D of T Frame

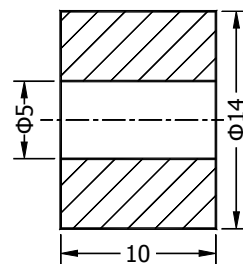

Part E of T Frame

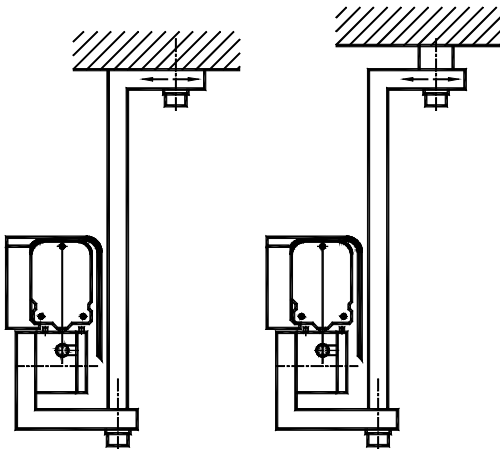

Fig. 22

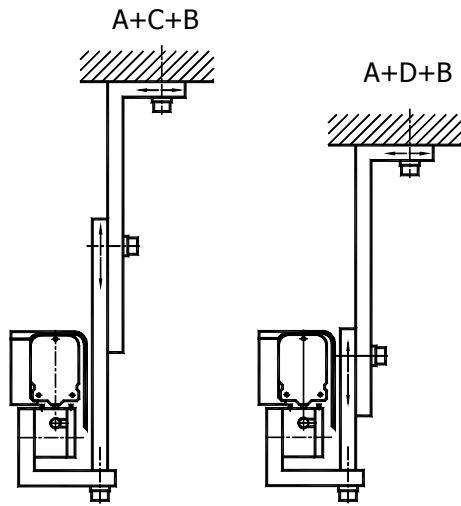

Fig. 23

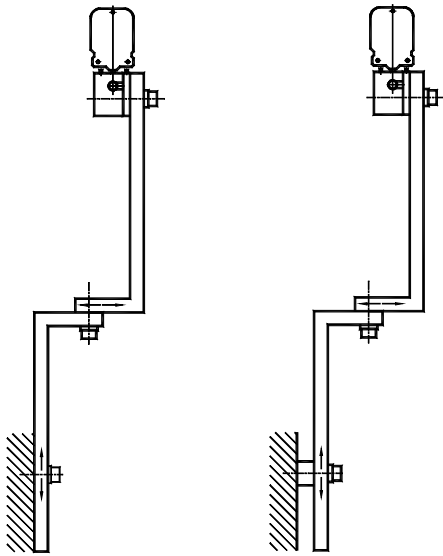
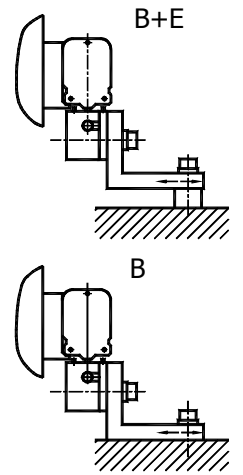

Fig. 24

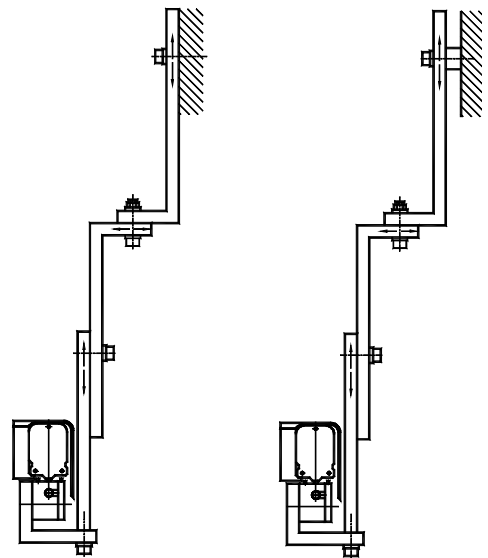

Fig. 25

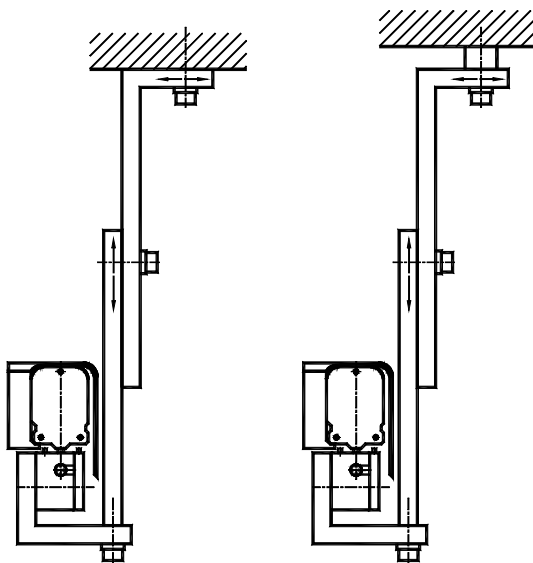

Fig. 26

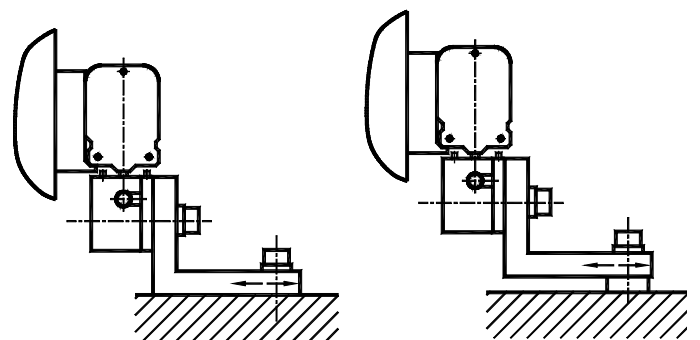

Fig. 27

Figures above applicable to installation of KA-300 and KA-600 scales

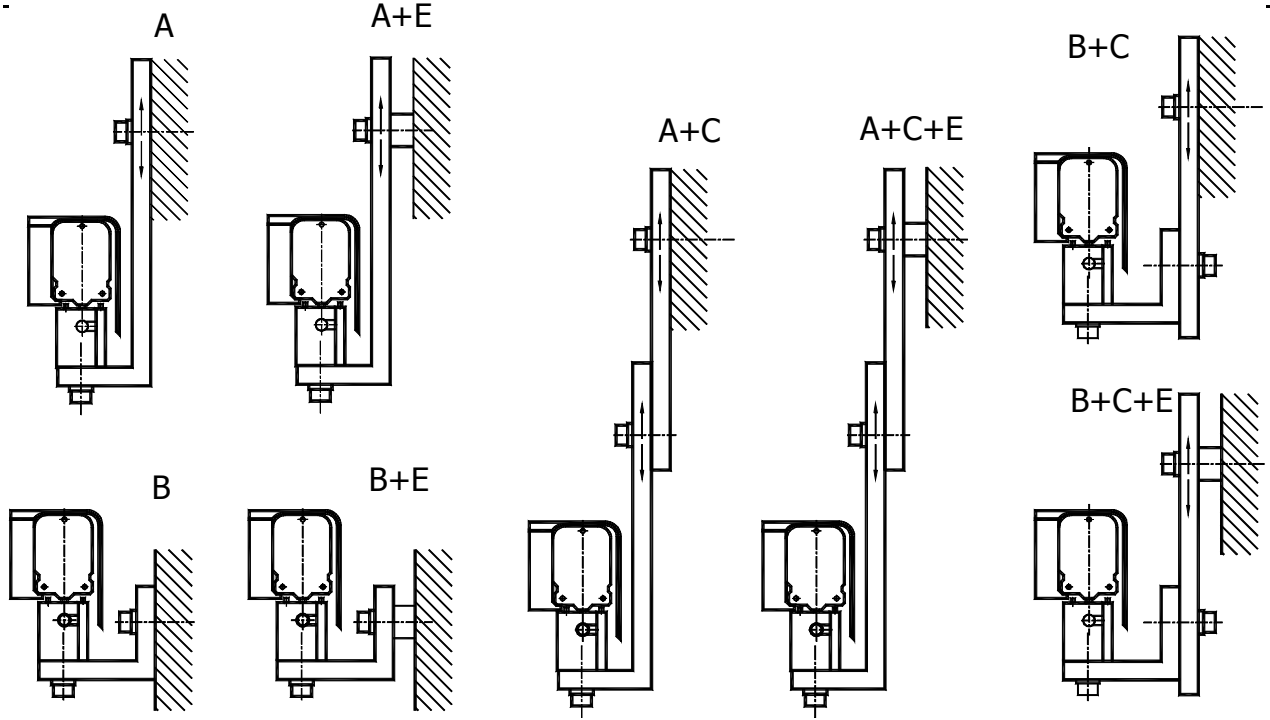

Fig. 28

Figures above applicable to installation of KA-300 and KA-600 scales

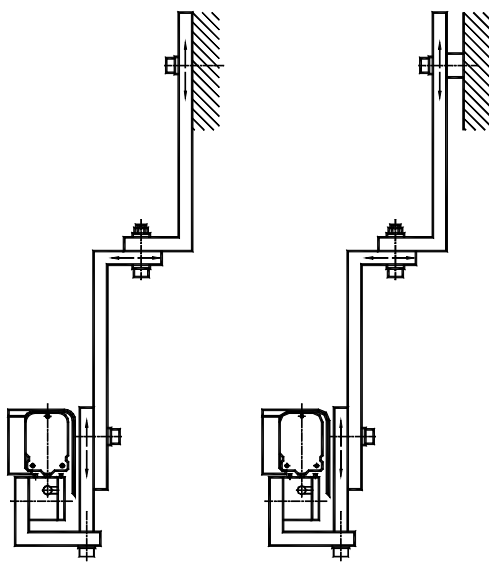

Fig. 29

A+A+C+B

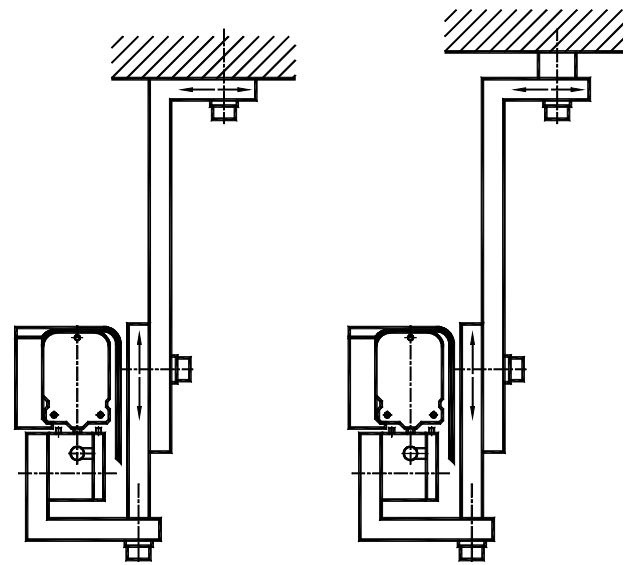

Fig. 30

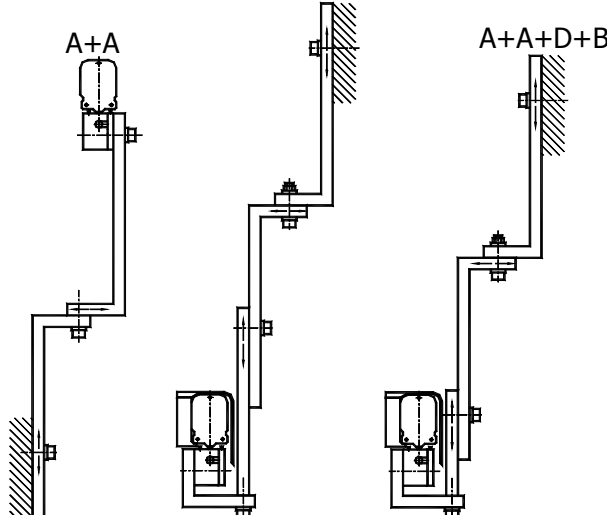
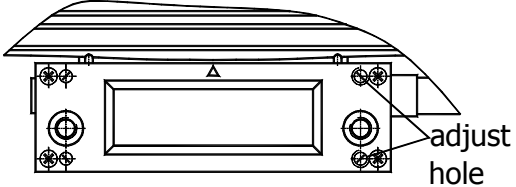

Fig. 31

Figures above applicable to installation of KA-300 and KA-600 scales

4.5 Rearrangement of Reading Head Cable

The cable of the reading head is arranged on the right in the factory. If it is inconvenient for use, the user may rearrange it in another direction in the following procedure:

- (1) Take out four M2 "+" setscrew in the figure cover and two M3 "-" bolt on the right of the cover. 
- (2) M4 hex bolt into the adjust screw holt and please do this one by one for flab the cover board which has airproof bar at the top, when noticing the gap. Please pry the cover board along the top by the screwdriver.
- (3) Loose two M3 "-" bolt of the moor cable, remove the cable and end. Exchange the orientation.
- (4) Before covering the cover board, you must clean the old airproof bar and wipe the new one, if do not have the new one, you can use butter order to instead of that, but the effect is not so good, only in support.
- (5) Take out of six M4 hex bolt, screw down the setscrew, fit on the cover board and the cover board bolt and adjust bolt.

Note: The tools used in taking down in each step is partnership, avoiding the screw head sleeking.

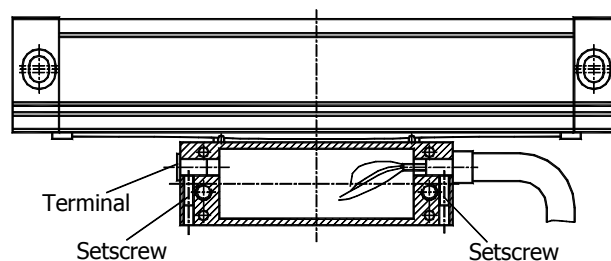

5. Checking installation

5.1 With the reading head securely fastened, if you shake it headlong, position display may fluctuate while shaking, but will always return to the same stable value if left alone.

5.2 The reading head should be centered in the scale body to ensure proper sealing as shown in Fig 32, Fig 33 and Fig 34.

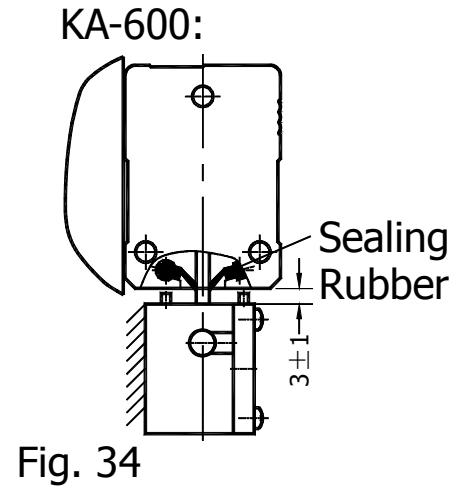
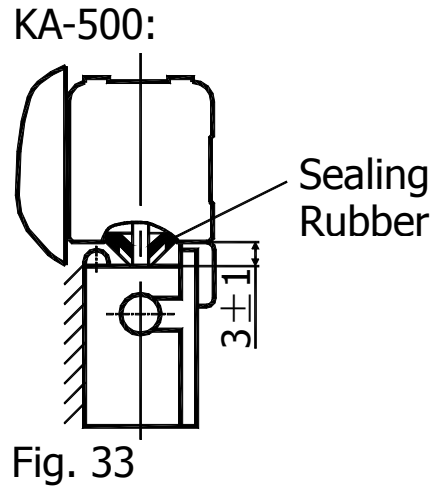
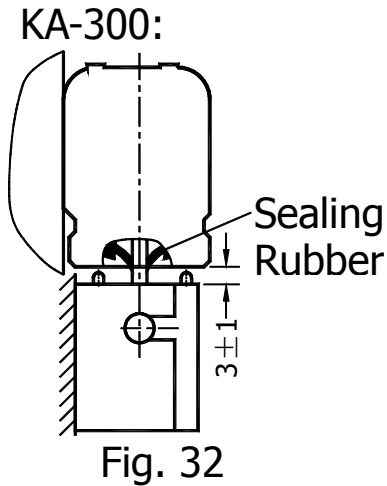

Sterling

8F-2, No. 97 Taichung Kang Rd, Sec,3., Taichung 40755, Taiwan.

Tel: 04 2358 8535 | Fax: 04 2358 8530 | info@dro.com.tw

www.dro.com.tw